



- APD Receiver
- Duplex LC connector
- 2-wire interface for management and diagnostic monitor
- XFI electrical interface with AC coupling
- Power supply voltages : +3.3V, +5V
- Temperature range -5°C to 70°C
- Power dissipation: <3.5W
- RoHS Compliant Part

Features:

- Support multi protocol from 9.95Gb/s to 11.1Gb/s
- Hot pluggable 30 pin connector
- Compliant with XFP MSA
- Transmission distance of 80km over single mode fiber
- 1550nm EML laser transmitter with Isolator.

Applications:

- 10GBASE-ZR/ZW Ethernet
- SONET OC-192/SDH STM-64
- 80km 10G FC

Description:

POFLink' PLX-10G-ZR Small Form Factor 10Gb/s (XFP) transceivers are compliant with the current XFP Multi-Source Agreement (MSA) Specification. The high performance cooled 1550nm EML transmitter and high sensitivity APD receiver provide superior performance for SONET/SDH and Ethernet applications up to 80km optical links..

Specification:

Absolute Maximum Ratings

Parameter	Symbol	Min	Max	Unit
Storage Temperature	TST	-40	+85	°C
Operating Temperature	TIP	-5	+70	°C
Supply Voltage 1	VCC3	-0.5	+4.0	V
Supply Voltage 2	VCC5	-0.5	+6.0	V
Supply Voltage 3	VCC2	-0.5	+2.0	V

Recommend Operation Environment:

Parameter	Symbol	Min	Typ	Max	Unit
Supply Voltage 1	VCC	+3.1	3.3	+3.5	V
Supply Voltage 2	VCC	+4.75	5.0	+5.25	V
Supply Voltage 3	VCC	+1.71	1.8	+1.89	V
Operating Temperature	TOP	-5	-	+70	°C

Electrical Characteristics (Condition: T_a=T_{OP})

Parameter	Symbol	Min	Typ	Max	Unit	Note	
Supply Voltage 1	Vcc5	4.75		5.25	V		
Supply Voltage 2	Vcc3	3.13		3.45	V		
Supply Voltage 3	VCC	1.71		1.89	V		
Supply Current - Vcc5 supply	Icc5			250	mA		
Supply Current - Vcc3 supply	Icc3			500	mA		
Supply Current - Vcc2 supply	Icc2			750	mA		
Module total power	P			3.5	W		
Transmitter							
Input differential impedance	Rin		100		Ω	1	
Differential data input swing	V _{in,pp}	150		1000	mV		
Transmit Disable Voltage	VD	2.0		Vcc	V		
Transmit Enable Voltage	VEN	GND		GND+ 0.8	V		
Transmit Disable Assert Time	T _{off}			10	us		
Tx Enable Assert Time	T _{on}			2	ms		
Receiver							
Differential data output swing	V _{out,pp}	300	600	850	mV		
Data output rise time	t _r	24	-	-	ps	2	
Data output fall time	t _f	24	-	-	ps	2	
LOS Fault	VLOS fault	Vcc - 0.5		VccHOST	V	3	
LOS Normal	VLOS norm	GND		GND+0.4	V	3	
Power Supply Rejection	PSR	See Note 4 below					4

1. After internal AC coupling.
2. 20 - 80 %
3. Loss Of Signal is open collector to be pulled up with a 4.7k - 10kohm resistor to 3.15 - 3.6V. Logic 0 indicates normal operation; logic 1 indicates no signal detected.
4. Per Section 2.7.1. in the XFP MSA Specification.

Optical Characteristics (Condition: $T_a=T_{OP}$)

Parameter	Symbol	Min	Typ	Max	Unit	Ref.
Transmitter						
Operating Date Rate	B	9.9		10.5	Gb/s	
Bit Error Rate	BER			10^{-12}		
Output Power	Po	0		+4	dBm	1
Optical Wavelength	λ	1530		1565	nm	
Optical Extinction Ratio	ER	8.2			dB	
Spectral Width	$\Delta\lambda$			1	nm	
Sidemode Supression ratio	SSRmin	30			dB	
Rise/Fall Time (20%~80%)	Tr/Tf			50	ps	
Average Launch power of OFF Transmitter	POFF			-30	dBm	
Tx Jitter	Txj	Compliant with each standard requirements				
Optical Eye Mask		IEEE802.3ae				2
Receiver						
Operating Date Rate	B	9.9		10.5	Gb/s	
Receiver Sensitivity@9.95Gb/s	R			-24	dBm	2
Receiver Sensitivity (OMA)@11.1Gb/s	RSENS			-23	dBm	2
Maximum Input Power	PMAX	-7			dBm	2
Optical Center Wavelength	λ_C	1528		1565	nm	
Receiver Reflectance	Rrx			-27	dB	
LOS De-Assert	LOSD			-24	dBm	
LOS Assert	LOSA	-34			dBm	
LOS Hysteresis	-	0.5	-	-	dB	

Notes:

1. The optical power is launched into SMF.
2. Measured with a PRBS $2^{-31}-1$ test pattern @11.1Gbps BER< 10^{-12} .

Pin Assignment:

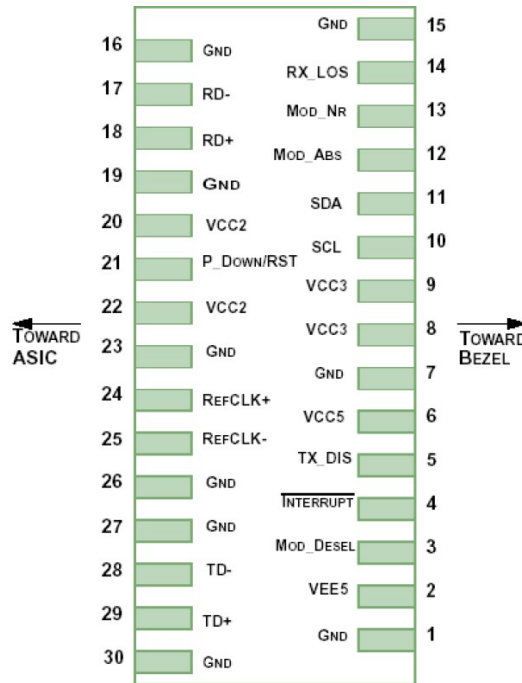

Diagram of Host Board Connector Block Pin Numbers and Name

Pin Description:

Pin	Logic	Symbol	Name/Descriptio	Ref.
1		GND	Module Ground	1
2		VEE5	Optional -5.2 Power Supply - Not required	
3	LVTTL-I	Mod-Desel	Module De-select; When held low allows the module to, respond to 2-wire serial nterface commands	
4	LVTTL-O	Interrupt	Interrupt (bar); Indicates presence of an important condition which can be read over the serial 2-wire interface	2
5	LVTTL-I	TX_DIS	Transmitter Disable; Transmitter laser source turned off	
6		VCC5	+5 Power Supply	
7		GND	Module Ground	1
8		VCC3	+3.3V Power Supply	
9		VCC3	+3.3V Power Supply	
10	LVTTL-I	SCL	Serial 2-wire interface clock	2
11	LVTTL- I/O	SDA	Serial 2-wire interface data line	2
12	LVTTL-O	Mod_Abs	Module Absent; Indicates module is not present. Grounded in the module.	2
13	LVTTL-O	Mod_NR	Module Not Ready;	2
14	LVTTL-O	RX_LOS	Receiver Loss of Signal indicator	2
15		GND	Module Ground	1
16		GND	Module Ground	1
17	CML-O	RD-	Receiver inverted data output	
18	CML-O	RD+	Receiver non-inverted data output	
19		GND	Module Ground	1
20		VCC2	+1.8V Power Supply - Not required	

21	LVTTL-I	P_Down/RST	Power Down; When high, places the module in the low power stand-by mode and on the falling edge of P_Down initiates a module reset	
			Reset; The falling edge initiates a complete reset of the module including the 2-wire serial interface, equivalent to a power cycle.	
22		VCC2	+1.8V Power Supply - Not required	
23		GND	Module Ground	1
24	PECL-I	Ref CLK+	Reference Clock non-inverted input, AC coupled on the host board	3
25	PECL-I	Ref CLK-	Reference Clock inverted input, AC coupled on the host board - Not required	3
26		GND	Module Ground	1
27		GND	Module Ground	1
28	CML-I	TD-	Transmitter inverted data input	
29	CML-I	TD+	Transmitter non-inverted data input	
30		GND	Module Ground	1

Note

1. Module circuit ground is isolated from module chassis ground within the module.
2. Open collector; should be pulled up with 4.7k - 10k ohms on host board to a voltage between 3.15V and 3.6V.
3. A Reference Clock input is not required .

Digital Diagnostic Functions:

As defined by the XFP MSA 1 , POFLink’s XFP transceivers provide digital diagnostic functions via a 2-wire serial interface, which allows real-time access to the following operating parameters:

- Transceiver temperature
- Laser bias current
- Transmitted optical power
- Received optical power
- Transceiver supply voltage

It also provides a sophisticated system of alarm and warning flags, which may be used to alert end-users when particular operating parameters are outside of a factory-set normal range.

The operating and diagnostics information is monitored and reported by a Digital Diagnostics Transceiver Controller (DDTC) inside the transceiver, which is accessed through the 2-wire serial interface. When the serial protocol is activated, the serial clock signal (SCL pin) is generated by the host. The positive edge clocks data into the XFP transceiver into those segments of its memory map that are not write-protected. The negative edge clocks data from the XFP transceiver. The serial data signal (SDA pin) is bi-directional for serial data transfer. The host uses SDA in conjunction with SCL to mark the start and end of serial protocol activation. The memories are organized as a series of 8-bit data words that can be addressed individually or sequentially. The 2-wire serial interface provides sequential or random access to the 8 bit parameters, addressed from 000h to the maximum address of the memory.

For more detailed information including memory map definitions, please see the XFP MSA Specification.

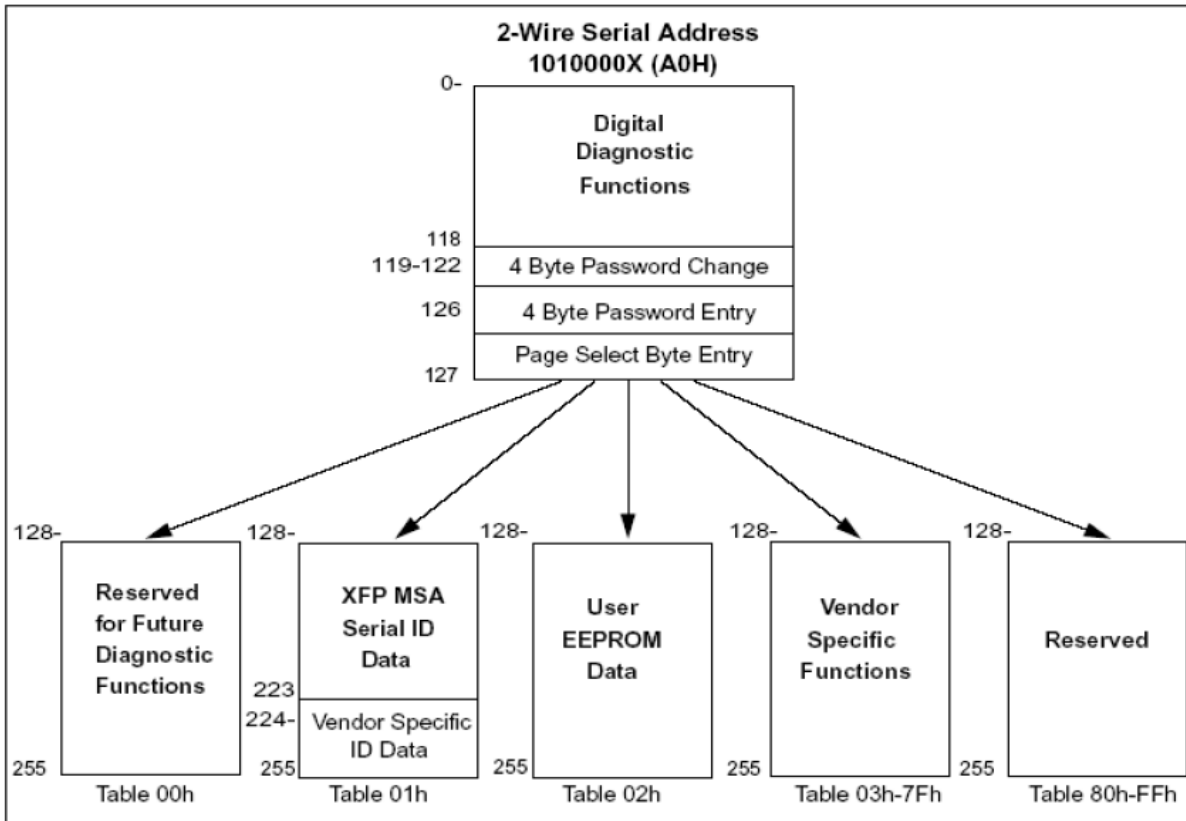

Recommended Circuit:

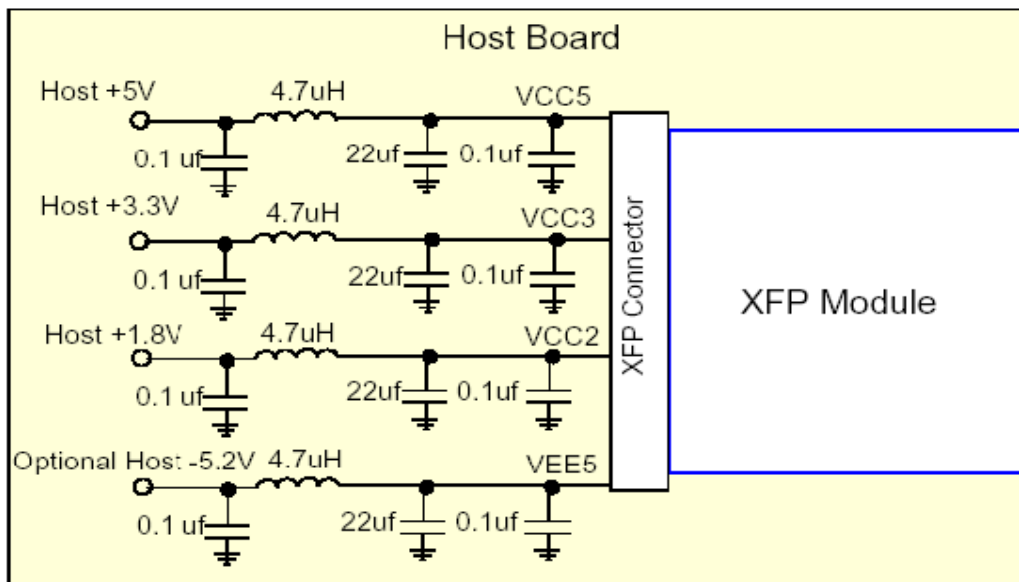

Recommended Host Board Power Supply Circuit

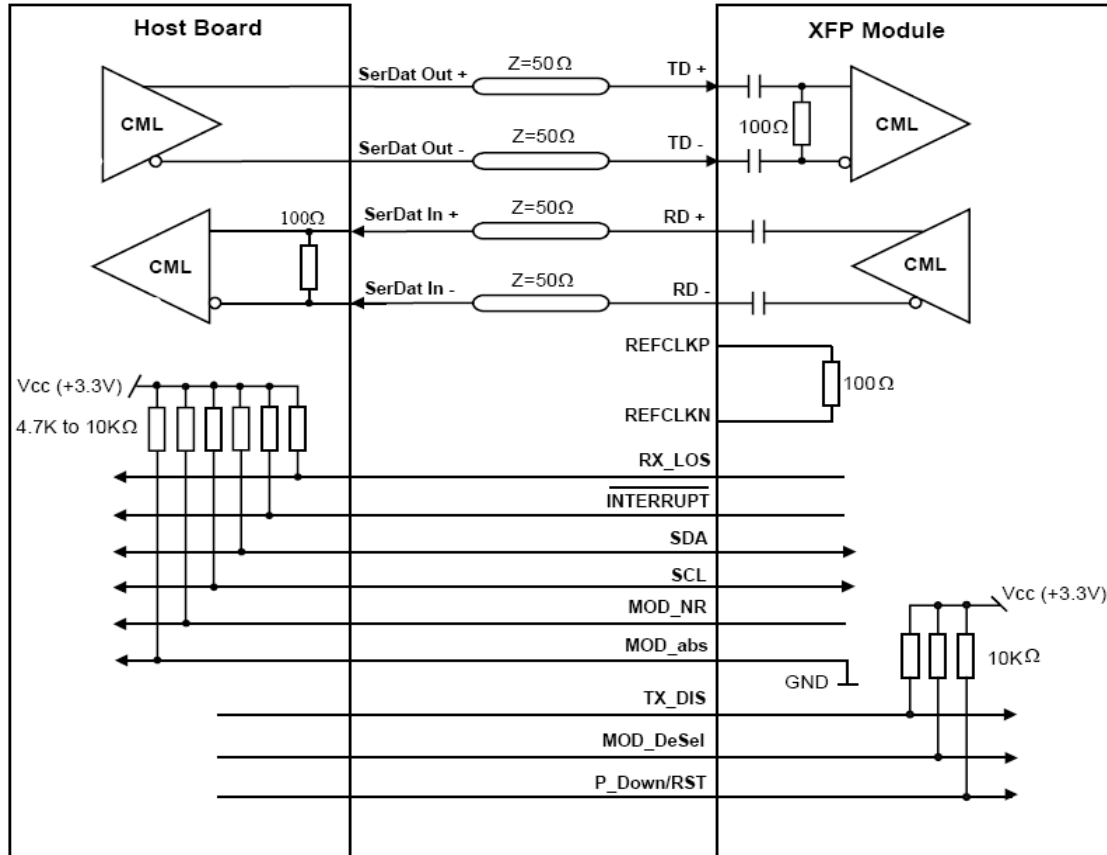

Recommended High-speed Interface Circuit

Mechanical Dimensions:

