



- Built-in digital diagnostic functions
- Temperature range 0°C to 70°C
- Transmission distance up to 300m (high bandwidth MMF; 2000MHz*Km)
- Very low EMI and excellent ESD protection
- Laser Class 1M compliant
- Fully compliant to XFP MSA Rev.4.5
- RoHS Compliant Part

Features:

- Supports 9.95Gb/s to 10.5Gb/s bit rates
- Hot-pluggable XFP footprint
- Vertical Cavity Surface Emitting Laser at 850nm(VCSEL).
- Duplex LC connector
- Low Power dissipation 1.5W(Typ)
- No Reference Clock required

Applications:

- 10 GBASE-SR 10G Ethernet at 10.3125 Gbit/s
- 1200-Mxx-SN-I 10G Fibre Channel 10.51875Gbit/s

Description:

POFLink' PLX-10G-SR is a multi-purpose optical transceiver module for 10Gbit/s data transmission applications at 850nm. It is ideally suited for 10 GbE datacom (belly-to-belly for high density applications) and storage area network(SAN/NAS) applications based on the IEEE 802.3ae and Fibre Channel standards. Designed for short range distances the transceiver module comprises a transmitter with a vertical cavity surface emitting laser (VCSEL) and a receiver with a PIN photodiode. Transmitter and receiver are separate within a wide temperature range of 0°C to +70°C and offers optimum heat dissipation and excellent electromagnetic shielding thus enabling high port densities for 10 GbE systems.

Regulatory Compliance:

Feature	Reference Standard	Performance
Electrostatic Discharge (ESD) to the Electrical Pins	MIL-STD-883E Method 3015.7	Class 1(>500 V)
Electromagnetic Interference (EMI)	FCC Part 15 Class B	Compatible with standards
Laser Eye Safety	FDA 21CFR 1040.10 and 1040.11 EN60950, EN (IEC) 60825-1,2	Compatible with Class I laser product.
Green Products	RoHS	RoHS6

Specification:

Electrical Characteristics (Condition: $T_a=TOP$)

Parameter	Symbol	Min	Typ	Max	Unit	Note
Main Supply Voltage	Vcc5	4.75		5.25	V	
Supply Voltage #2	Vcc3	3.13		3.45	V	
Supply Current - Vcc5 supply	Icc5			250	mA	
Supply Current - Vcc3 supply	Icc3			500	mA	
Module total power	P			2.5	W	
Transmitter						
Input differential impedance	Rin		100		Ω	1
Differential data input swing	Vin,pp	120		1200	mV	
Transmit Disable Voltage	VD	2.0		Vcc	V	
Transmit Enable Voltage	VEN	GND		GND+ 0.8	V	
Transmit Disable Assert Time				10	us	
Receiver						
Differential data output swing	Vout,pp	340	650	850	mV	
Data output rise time	tr			38	ps	2
Data output fall time	tf			38	ps	2
LOS Fault	VLOS fault	Vcc - 0.5		VccHOST	V	3
LOS Normal	VLOS norm	GND		GND+0.5	V	3
Power Supply Rejection	PSR		See Note 4 below			4

1. After internal AC coupling.

2. 20 - 80 %

3. Loss Of Signal is open collector to be pulled up with a 4.7k - 10kohm resistor to 3.15 - 3.6V. Logic 0 indicates normal operation; logic 1 indicates no signal detected.

4. Per Section 2.7.1. in the XFP MSA Specification.

Optical Characteristics (Condition: $T_a=TOP$)

Parameter	Symbol	Min	Typ	Max	Unit	Ref.
Transmitter						
Operating Data Rate	B	9.9		10.5	Gb/s	
Bit Error Rate	BER			10^{-12}		
Optical Modulation Amplitude (OMA)	POMA	-4.3		-	dBm	1
Maximum Launch Power	PMAX	-7.3		-1.0	dBm	1
Optical Wavelength	λ	840		860	nm	
Optical Extinction Ratio	ER	3.5	5.5		dB	
Tx Jitter	Txj	Compliant with each standard requirements				
Optical Eye Mask		IEEE802.3ae				2

Receiver						
Operating Data Rate	B	9.9		10.5	Gb/s	
Receiver Sensitivity	R			-11.1	dBm	2
Receiver Sensitivity (OMA)@10.5Gb/s	RSENS			-7.5	dBm	2
Maximum Input Power	P _{MAX}	+0.5			dBm	2
Optical Center Wavelength	λ C	840		860	nm	
Receiver Reflectance	R _{rx}			-12	dB	
LOS De-Assert	LOSD			-12	dBm	
LOS Assert	LOSA	-25			dBm	
LOS Hysteresis		1			dB	

Notes:

1. The optical power is launched into MMF.
2. Measured with a PRBS $2^{-31}-1$ test pattern @10.3125Gbps BER< 10^{-12} .

Absolute Maximum Ratings

Parameter	Symbol	Min	Max	Unit
Storage Temperature	T _{ST}	-40	+85	°C
Operating Temperature	T _{IP}	-5	+70	°C
Supply Voltage 1	VCC3	-0.5	+4.0	V
Supply Voltage 1	VCC5	-0.5	+6.0	V

Recommend Operation Environment:

Parameter	Symbol	Min	Typ	Max	Unit
Supply Voltage 1	VCC	+3.1	3.3	+3.5	V
Supply Voltage 1	VCC	+4.75	5.0	+5.25	V
Operating Temperature	T _{OP}	-5	-	+70	°C

Pin Assignment:

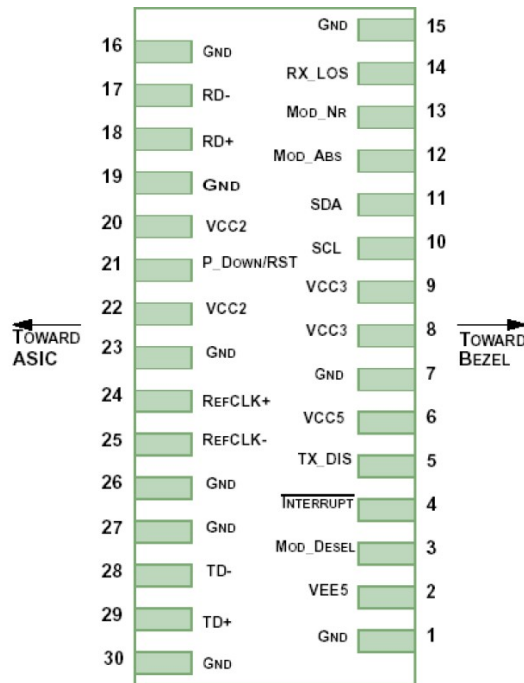

Diagram of Host Board Connector Block Pin Numbers and Name

Pin Description

Pin	Logic	Symbol	Name/Descriptio	Ref.
1		GND	Module Ground	1
2		VEE5	Optional -5.2 Power Supply - Not required	
3	LVTTL-I	Mod-Desel	Module De-select; When held low allows the module to, respond to 2-wire serial	
4	LVTTL-O	Interrupt	Interrupt (bar); Indicates presence of an important condition which	2
5	LVTTL-I	TX_DIS	Transmitter Disable; Transmitter laser source turned off	
6		VCC5	+5 Power Supply	
7		GND	Module Ground	1
8		VCC3	+3.3V Power Supply	
9		VCC3	+3.3V Power Supply	
10	LVTTL-I	SCL	Serial 2-wire interface clock	2
11	LVTTL-I/O	SDA	Serial 2-wire interface data line	2
12	LVTTL-O	Mod_Abs	Module Absent; Indicates module is not present. Grounded in the module.	2
13	LVTTL-O	Mod_NR	Module Not	2
14	LVTTL-O	RX_LOS	Receiver Loss of Signal indicator	2
15		GND	Module Ground	1
16		GND	Module Ground	1
17	CML-O	RD-	Receiver inverted data output	
18	CML-O	RD+	Receiver non-inverted data output	

19		GND	Module Ground	1
20		VCC2	+1.8V Power Supply - Not required	
21	LVTTTL-I	P_Down/RST	Power Down; When high, places the module in the low power stand-by mode and on the falling edge of P_Down initiates a module reset	
			Reset; The falling edge initiates a complete reset of the module including the 2-wire serial interface, equivalent to a power cycle.	
22		VCC2	+1.8V Power Supply - Not required	
23		GND	Module Ground	1
24	PECL-I	RefCLK+	Reference Clock non-inverted input, AC coupled on the host board - Not required	3
25	PECL-I	RefCLK-	Reference Clock inverted input, AC coupled on the host board - Not required	3
26		GND	Module Ground	1
27		GND	Module Ground	1
28	CML-I	TD-	Transmitter inverted data input	
29	CML-I	TD+	Transmitter non-inverted data input	
30		GND	Module Ground	1

Note

1. Module circuit ground is isolated from module chassis ground within the module.
2. Open collector; should be pulled up with 4.7k - 10k ohms on host board to a voltage between 3.15V and 3.6V.
3. A Reference Clock input is not required .

Digital Diagnostic Functions:

As defined by the XFP MSA 1 , POFLINK’s XFP transceivers provide digital diagnostic functions via a 2-wire serial interface, which allows real-time access to the following operating parameters:

- Transceiver temperature
- Laser bias current
- Transmitted optical power
- Received optical power
- Transceiver supply voltage

It also provides a sophisticated system of alarm and warning flags, which may be used to alert end-users when particular operating parameters are outside of a factory-set normal range.

The operating and diagnostics information is monitored and reported by a Digital Diagnostics Transceiver Controller (DDTC) inside the transceiver, which is accessed through the 2-wire serial interface. When the serial protocol is activated, the serial clock signal (SCL pin) is generated by the host. The positive edge clocks data into the XFP transceiver into those segments of its memory map that are not write-protected. The negative edge clocks data from the XFP transceiver. The serial data signal (SDA pin) is bi-directional for serial data transfer. The host uses SDA in conjunction with SCL to mark the start and end of serial protocol activation. The memories are organized as a series of 8-bit data words that can be addressed individually or sequentially. The 2-wire serial interface provides sequential or random access to the 8 bit parameters, addressed from 000h to the maximum address of the memory.

For more detailed information including memory map definitions, please see the XFP MSA Specification.

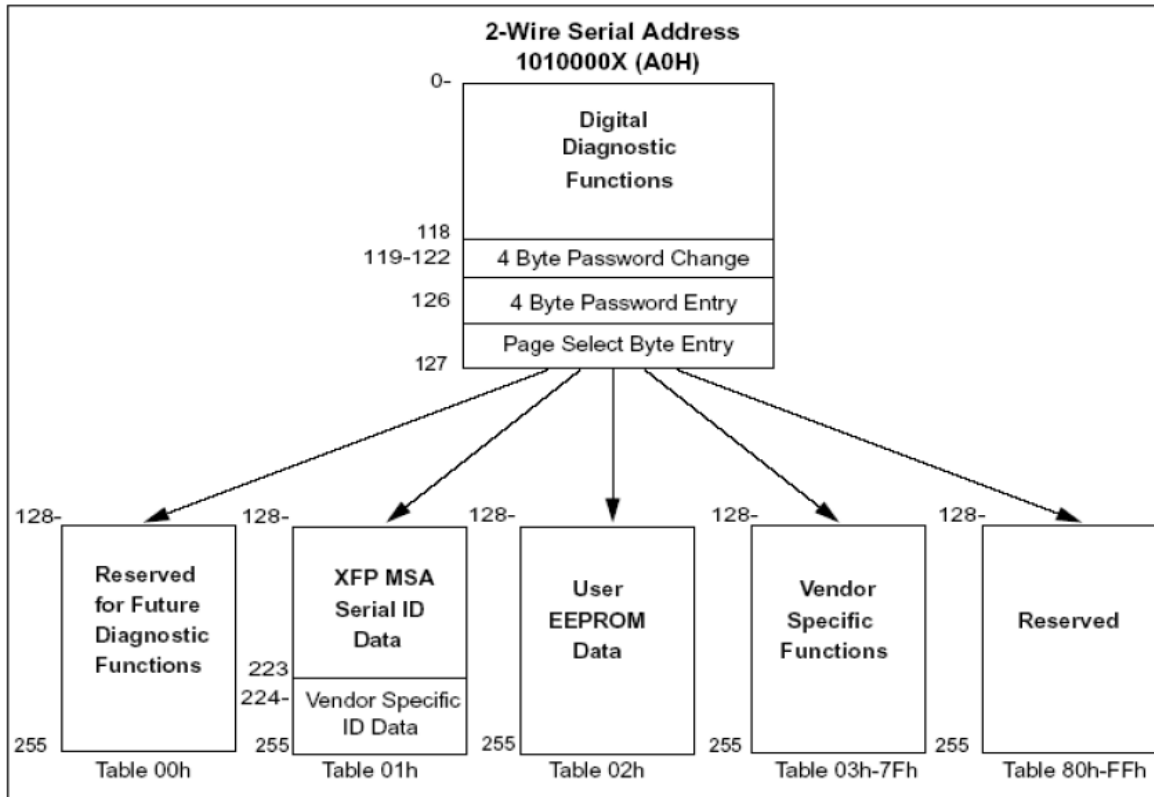

Recommended Circuit:

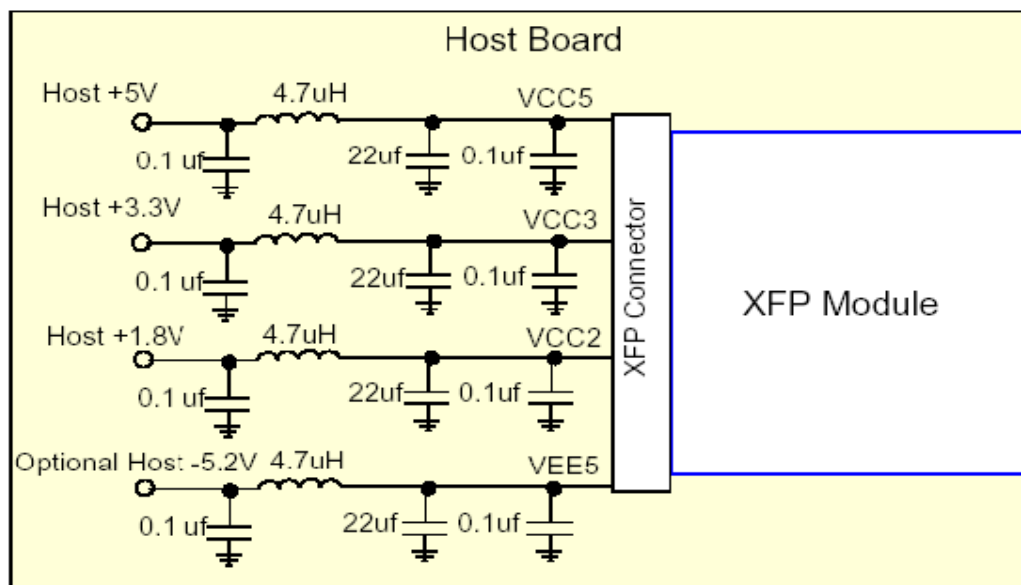

Recommended Host Board Power Supply Circuit

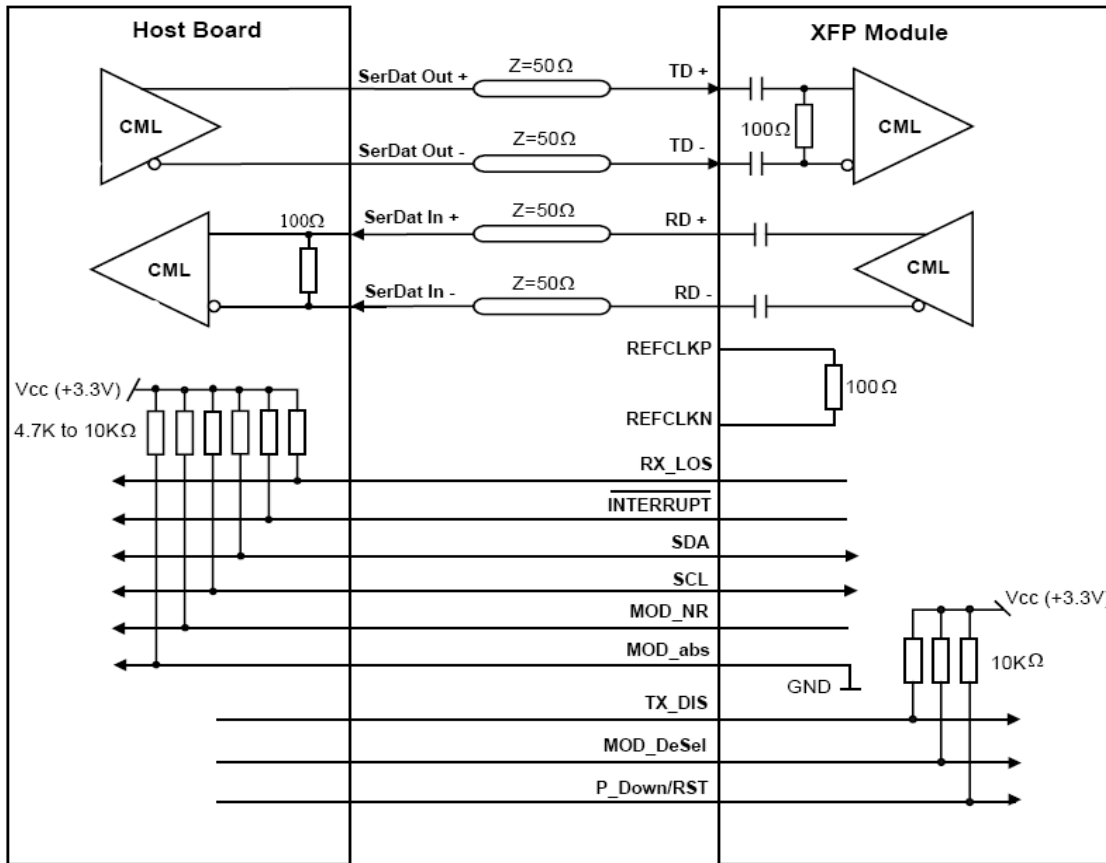

Recommended High-speed Interface Circuit

Mechanical Dimensions:

